



# WLDS1V Water Leak Detection Installation and Operation Manual



## Contents

- 1) **Operation**
- 2) **Water Detected Alarm**
- 3) **Positioning the water detection cable**
- 4) **Fitting Cable clips**
- 5) **Water shutdown Valve**
- 6) **Temporary valve shutdown override**
- 7) **Installation**
- 8) **Water Detection Sensitivity Adjustment**
- 9) **Commissioning**
- 10) **Fault Diagnoses**

## 1) Operation

In normal mode with no alarms or faults, the audible warning device will be OFF, and green lamp will be ON.

## 2) Water Detected Alarm

When the detection cable comes into contact with water anywhere along its length, the audible warning device will start, the BMS alarm relay will close and the lamp will start flashing between green and red. To stop the audible warning press the "Mute Alarm" button. On muting, the lamp will stop flashing and remain permanently red, indicating an acknowledged alarm. The system will remain in this state until the water is removed from the cable, when the lamp will turn green and BMS alarm relay turn OFF.

## 3) Positioning the water detection cable

Terminate the white cables red and black wired to the terminal block marked "Sensor". As cable termination is NOT polarity conscious, any wire can go into any terminal. Note: The detection cable is susceptible to damage and should not be fitted to areas where the cable is likely to be damaged or walked on.

## 4) Fitting Cable Clips

If Cable Clips are required, to protect the small sensor wires and to stop false water detected alarms from occurring insulating tape should be first applied around the detection cable before the clip tongue is closed. Clips should be fitted approximately every 1 to 1.5 meters apart. When using clips make sure that the cable touches the floor between the clips, **DO NOT** tighten the cable so that the cable does not touch the floor.

Insulating Tape  
Under the fixing  
clip tongue



## 5) Water Shutdown Valve

A 230VAC supply has been provided from the terminal block marked "Valve" to power a solenoid valve fitted to the water feed pipe. If a water leak is detected by the unit, this supply will be removed thereby shutting the valve. Once the leak has been rectified the detection cable may take some hours to dry out.



## 6) Temporary valve shutdown override

During the detection cable drying out period, the water valve can be opened by pressing the "Mute" push Button for at least 5 seconds. Once the cable has dried out the override will automatically be cancelled

## 7) Installation

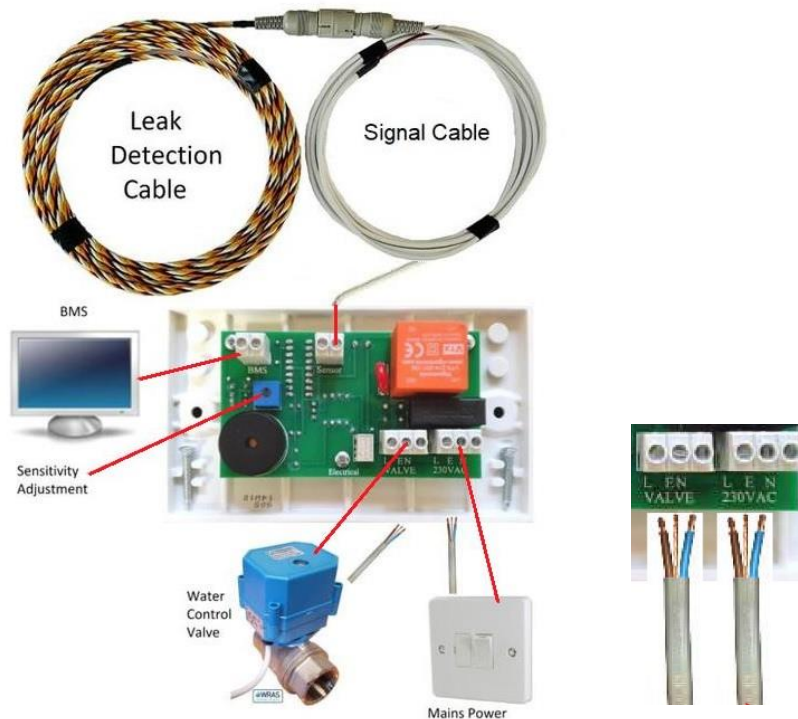

**THIS EQUIPMENT SHOULD INSTALLED BY A QUALIFIED ELECTRICIAN.**

A suitably rated 230VAC power cable supply should be run from a fused spur to the unit and terminated to the internal terminal block marked 230VAV “L”, “E” & “N”. The fuse within the fused spur should be rated at 5 Amps.

**8) Water Detection Sensitivity Adjustment**

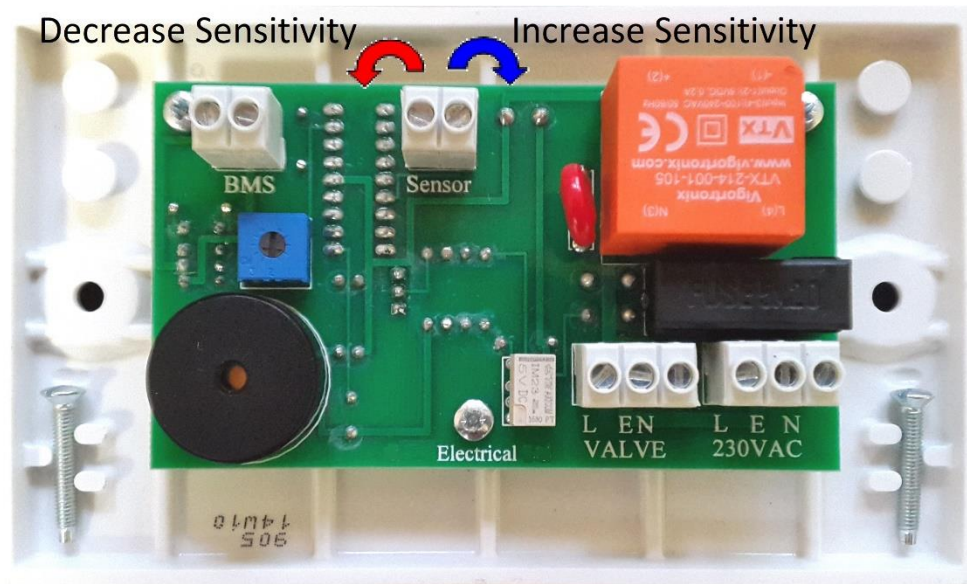

**9) Commissioning**

Having connected the unit as described above, turn of the mains power to the unit. The lamp should illuminate green. If not, refer to the “Fault Diagnostics” below. If the unit powers up with the audible warning going and the light flashing green / red, press the mute button and wait to see if the alarm clears.If the alarm remains ON after approximately 20 seconds, refer to the “Fault Diagnostics” below. Using a cup of CLEAN water, immerse a small area (50mm long) of cable into the water. The controller lamp should start to flash green / red, the audible warning device should be ON and the valve should stop the flow of water, if not refer to the “Fault Diagnostics” below. With the lamp flashing, press the “Mute” button. The audible warning device should stop and the lamp should stop flashing but remain ON. Remove the water and wipe the cable with some tissue, the lamp should turn green, if not refer to the “Fault Diagnostics” below.

**10) Fault Diagnoses**

Fault	Possible Reason
Lamp is OFF and the unit appears dead	No power to the control unit. Test with a meter The power fuse has blown. Test the fuse with a meter
Water Detected lamp remains ON all the time.	The cable needs drying out after detecting water. Using tissue paper dry the cable. The cable has a short between the sensors due to Contaminants. Clean the cable using water and tissue paper dry out afterwards. The cable has been damaged. Visually check the cable for damage. The sensitivity of the detection system is too sensitive turn the potentiometer until the system resets. System fault. Return to manufacture
When the system has a water detected alarm, the lamp remains OFF, but the audible warning devise sounds.	Lamp fault. Return to manufacture
The system will not record a water detected alarm, the lamp remains green and audible warningdevise remain OFF	Sensitivity could be too low or a Possible system fault turn the potentiometer until the system goes into alarm. System fault. Return to manufacture
Horn not working	Faulty horn. Return to manufacture
The water valve will not open	No power to the valve. Check that 230VAC is applied to the valves.
The water valve will not fully close	If possible open valve for 30 seconds (press alarm button for 7-8 seconds) to recharge valve battery.