

2/2 DIRECT ACTING NORMALLY OPEN SOLENOID VALVE

TYPE	PRESSURE

TYPE	PRESSURE

TYPE	PRESSURE
20201	0 - 20 bar
20202	0 - 63 bar

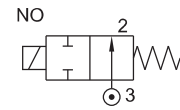

FEATURES

- Bubble tight shut off
- Manual override optionally provided
- Suitable for vacuum up to 10^{-6} torr
- Vibration resistance up to 9g
- Suitable for high speed cycling
- Speed up to 1000 cycles/ min
- Life >10 million cycles



WETTED PARTS

Code	✕	B2	B5
Body	Anodized Aluminium	Brass	SS 316
Internals	Aluminium	Brass	SS 316
Guide Assembly	SS 304		
Shadow-Ring	Copper/ Silver/ None		
Plunger, Insert	SS 430		
Spring	SS 302		
Seat, Seals	NBR, Viton, EPDM, PTFE		

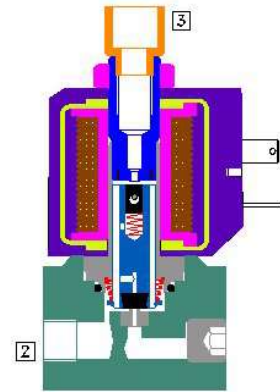

AMBIENT AND FLUID TEMPERATURE

-30 °C to 75 °C

SPECIAL VERSION AND SUFFIX

Suffix : (Valve) OX, AM
Special version : (Solenoid) CO, FR, SS, LC, III, TM

MEDIA

Air, Inert Gases, Water, Vacuum, Free Flowing Liquid, Oil, Diesel, Kerosene, LPG, Furnace Oil

APPLICATION

Drain and Dispensing

PORT CONNECTION

INLET	OUTLET
3	2

- Contact Rotex for
- Any other ambient, fluid temperature, media and application
 - UL listed, Listed general purpose Valve



OIL Media Temperature Restricted from 0 °C to 100 °C

SPARES

(Refer page 25 for ordering code)

SPARE KIT	CODE
Seal Kit : Oring Set and Plunger Assembly	98
Repair Kit : Oring Set, Plunger Assembly, Springs, Manual Override, Guide Assembly	99
Solenoid Kit : Solenoid, Gasket	34

APPROVAL

(* applied for)

Approval	Nema 4X	IP67	Ex d IIC T4 or T5 or T6 IP66	Ex ia IIC T6 IP67	DGMS	CCOE
		✓	✓	✓	✓	✓
CE		✓	✓	✓		
UL	✓		*			
			✓	✓		
			✓	✓		
			✓	✓		

2/2 DIRECT ACTING NORMALLY OPEN SOLENOID VALVE

SPECIFICATION

PORT CONNECTION			PRE-SSURE bar		ORIFICE (mm)	FLOW FACTOR kv (LPM OF WATER @ 1 bar ΔP)	VALVE TYPE	PILOT PRESSURE	BODY MATERIAL AND INTERNALS					SEALS				MANUAL OVERRIDE			SOLENOID ENCLOSURE				SUFFIX		POWER VA		CONSTRUCTION REFERENCE NUMBER
SIZE	BSP(F)	NPT(F)	MINIMUM	MAXIMUM					ALUMINIUM	ALUMINIUM + SS	BRASS (STD. PORT NPT)	SS 316 (STD. PORT NPT)	NBR	Viton	EPDM	HYTREL	PTFE	NIL	STAYPUT CUM MOMENTARY	MOMENTARY	FLYING LEAD	PLUG IN, IP67	SQ. PLUG IN, IP67	TERMINAL BOX IP67	EXPLOSION PROOF IIC, IP67	LARGE ENCLOSURE	SOLENOID SIZE	OXYGEN	

2/2 NORMALLY OPEN

SIZE	PORT CONNECTION	ORIFICE (mm)	FLOW FACTOR kv (LPM OF WATER @ 1 bar ΔP)	VALVE TYPE	PILOT PRESSURE	ALUMINIUM	ALUMINIUM + SS	BRASS (STD. PORT NPT)	SS 316 (STD. PORT NPT)	NBR	Viton	EPDM	HYTREL	PTFE	NIL	STAYPUT CUM MOMENTARY	MOMENTARY	FLYING LEAD	PLUG IN, IP67	SQ. PLUG IN, IP67	TERMINAL BOX IP67	EXPLOSION PROOF IIC, IP67	LARGE ENCLOSURE	SOLENOID SIZE	OXYGEN	AMONIA	AC INRUSH	AC HOLDING	DC	CONSTRUCTION REFERENCE NUMBER
1/2"	4G	4R	0 3 5 8 20202	×	B2	B5	×	S2	S1	S8	×	M6	M8	F	25	T	E	18	✓	✓	13	13	13	K						
			0 4 3 4 20201	×	B2	B5	×	S2	S1	S8	×	M6	M8	F	22	25	T	E	III	14	✓	✓	18	12	8	J				
			0 6 2.5 3.5 20201	×	B2	B5	×	S2	S1	S8	×	M6	M8	F	22	25	T	E	III	14	✓	✓	18	12	8	J				
			0 6 4 7 20202	×	B2	B5	×	S2	S1	S8	×	M6	M8	F	25	T	E	18	✓	✓	13	13	13	K						
	3G	3R	0 8 2.2 2.5 20201	×	B2	B5	×	S2	S1	S8	×	M6	M8	F	22	25	T	E	III	14	✓	✓	18	12	8	J				
			0 8 3.5 5 20202	×	B2	B5	×	S2	S1	S8	×	M6	M8	F	25	T	E	18	✓	✓	13	13	13	K						
			0 10 1.8 1.8 20201	×	B2	B5	×	S2	S1	S8	×	M6	M8	F	22	25	T	E	III	14	✓	✓	18	12	8	J				
			0 12 3 4 20202	×	B2	B5	×	S2	S1	S8	×	M6	M8	F	25	T	E	18	✓	✓	13	13	13	K						
	2G	2R	0 15 1.6 1.4 20201	×	B2	B5	×	S2	S1	S8	×	M6	M8	F	22	25	T	E	III	14	✓	✓	18	12	8	J				
			0 15 2.5 3.5 20202	×	B2	B5	×	S2	S1	S8	×	M6	M8	F	25	T	E	18	✓	✓	13	13	13	K						
			0 20 1.2 0.7 20201	×	B2	B5	×	S2	S1	S8	×	M6	M8	F	22	25	T	E	III	14	✓	✓	18	12	8	J				
			0 25 2.2 2.5 20202	×	B2	B5	×	S2	S1	S8	×	M6	M8	F	25	T	E	18	✓	✓	13	13	13	K						
1G	1R	0 32 1.8 1.8 20202	×	B2	B5	×	S2	S1	S8	×	M12	M5	F	25	T	E	18	✓	✓	13	13	13	K							
		0 40 1.6 1.4 20202	×	B2	B5	×	S2	S1	S8	×	M12	M5	F	25	T	E	18	✓	✓	13	13	13	K							
		0 63 1.2 0.7 20202	×	B2	B5				S8	×	M11	M4	F	25	T	E	18	✓	✓	13	13	13	K							
		0 120 0.8 0.5 20202V01	×	B2	B5				S8	×	M11	M4	F	25	T	E	18	✓	✓	13	13	13	K							

SOLENOID 14						
Cable Entry	T	E			Ex emb	
		Ex d	Ex ia	Ex mb		
M20 x 1,5	19 17MS	39 87MS	66MS	58MS	58LTMS	
M25 x 1,5	17	87	66	58	58LT	
1/2" NPT	16 17NS	37 87NS	66NS	58NS	58LTNS	

SOLENOID 18						
Cable Entry	T	E			Ex emb	
		Ex d	Ex ia	Ex mb		
M20 x 1,5	19 17MS	39 87MS		58MS	58LTMS	
M25 x 1,5	17	87		58	58LT	
1/2" NPT	16 17NS	37 87NS		58NS	58LTNS	

Code	Construction Reference
J	16, 18, 20, 22
K	17, 19, 21, 26
G	23, 27
H	24, 25

× = Do not specify when opted for. Refer Page # 22 for Value of ×
 ✓ = Options available

	F
Flying lead IP54	×
Flying lead IP67	01

ORDERING CODE AND EXAMPLE VALVE + SOLENOID

VALVE TYPE – SIL – SUFFIX – ORIFICE – PORT CONNECTION – BODY AND INTERNALS – MANUAL OVERRIDE – SEAL – MEDIA + SIZE – VOLTAGE – CURRENT – SOLENOID ENCLOSURE – SPECIAL VERSION – POWER – INSULATION – APPROVAL – SIL – ACCESSORIES SOLENOID

eg.: 20202- 5-3G+III-110V-DC-16; 20201-3-2R-B2-M8-S1+III-48V-DC-16

2/2 DIRECT ACTING NORMALLY OPEN SOLENOID VALVE

DIMENSIONS

All Dimensions are in mm

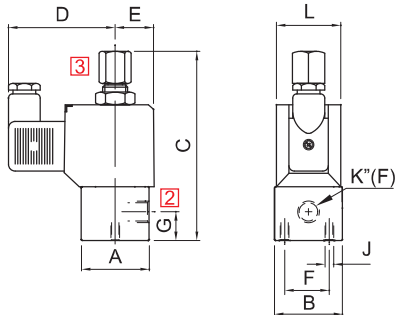

PLUG IN SOLENOID TYPE 22

K (PORT SIZE)	A	B	C	D	E	F	G	J	L	BODY MATL.	CONST. REF.
VALVE TYPE : 20201											
1/8"	38	38	103	60	22	25	16	M6	36	AL, BR	16
3/8", 1/2"	60	38	115	60	22	25	20.5	M6	36	AL, BR	17
1/8", 1/4"	44	Ø48	111	60	22	25	17	M6	36	SS	18
3/8", 1/2"	58	Ø62	131	60	22	25	14	M6	36	SS	19

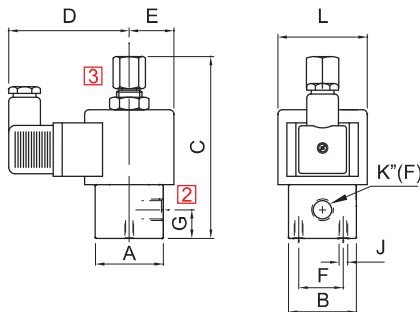

SQUARE PLUG IN SOLENOID TYPE 25

K (PORT SIZE)	A	B	C	D	E	F	G	J	L	BODY MATL.	CONST. REF.
VALVE TYPE : 20201											
1/8", 1/4"	38	38	103	66	25	25	16	M6	Ø50	AL, BR	20
1/8", 1/4"	60	38	115	66	25	25	20.5	M6	Ø50	AL, BR	21
1/8", 1/4"	44	Ø48	111	66	25	25	17	M6	Ø50	SS	22
1/2"	58	Ø62	131	68	29	25	14	M6	Ø50	SS	26
VALVE TYPE : 20201											
1/8", 1/4"	50	50	124	68	25	25	17	M6	Ø50	AL, BR	23
1/8", 1/4"	65	50	124	68	25	25	14	M6	Ø50	AL, BR	24
3/8", 1/2"	58	Ø62	131	68	29	25	14	M6	Ø50	SS	25
1/4"	44	Ø48	111	68	25	25	17	M6	Ø50	SS	27

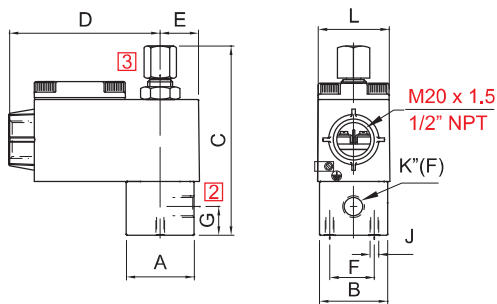

TERMINAL BOX/ Ex d ENCLOSURE, TYPE 16, 19, 37, 39, 58, 58LT

K (PORT SIZE)	A	B	C	D	E	F	G	J	L	BODY MATL.	CONST. REF.
VALVE TYPE : 20201											
1/8", 1/4"	38	38	103	85	22	25	16	M6	36	AL, BR	16
1/8", 1/4"	60	38	115	85	22	25	20.5	M6	36	AL, BR	17
1/8", 1/4"	44	Ø48	111	85	22	25	17	M6	36	SS	18
1/8", 1/4"	58	Ø62	131	85	22	25	14	M6	36	SS	19

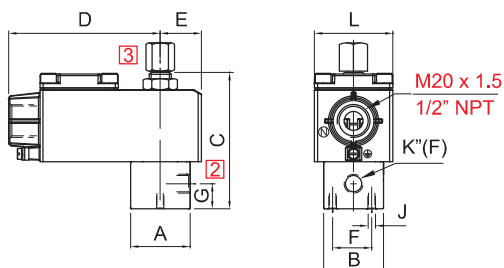

TERMINAL BOX/ Ex d LARGE ENCLOSURE, TYPE 16, 19, 37, 39, 58, 58LT, LC

K (PORT SIZE)	A	B	C	D	E	F	G	J	L	BODY MATL.	CONST. REF.
VALVE TYPE : 20201											
1/8", 1/4"	38	38	103	97	26	25	16	M6	50	AL, BR	20
3/8", 1/2"	60	38	115	97	26	25	20.5	M6	50	AL, BR	21
1/8", 1/4"	44	Ø48	111	97	26	25	17	M6	50	SS	22
1/2"	58	Ø62	131	103	29	25	14	M6	50	SS	26
VALVE TYPE : 20202											
1/8", 1/4"	50	50	124	103	28	25	17	M6	50	AL, BR	23
3/8", 1/2"	65	50	124	103	28	25	14	M6	50	AL, BR	24
3/8", 1/2"	58	Ø62	131	103	29	25	14	M6	50	SS	25
1/4"	44	Ø48	111	97	25	25	17	M6	50	SS	27

2/2 DIRECT ACTING NORMALLY OPEN SOLENOID VALVE

DIMENSIONS

All Dimensions are in mm

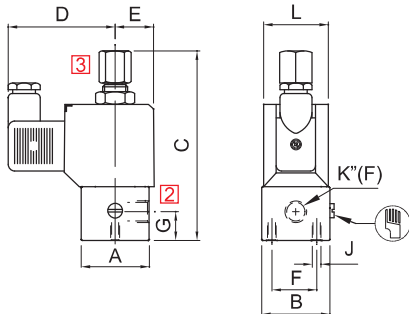

PLUG IN SOLENOID TYPE 22

K (PORT SIZE)	A	B	C	D	E	F	G	J	L	BODY MATL.	CONST. REF.
VALVE TYPE : 20201											
1/8", 1/4"	38	38	103	60	22	25	16	M6	36	AL, BR	16
3/8", 1/2"	60	38	115	60	22	25	20.5	M6	36	AL, BR	17
1/8", 1/4"	44	Ø48	111	60	22	25	17	M6	36	SS	18
3/8", 1/2"	58	Ø62	131	60	22	25	14	M6	36	SS	19

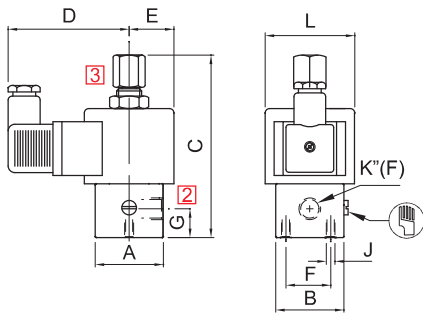

SQUARE PLUG IN SOLENOID TYPE 25

K (PORT SIZE)	A	B	C	D	E	F	G	J	L	BODY MATL.	CONST. REF.
VALVE TYPE : 20201											
1/8", 1/4"	38	38	103	68	25	25	16	M6	Ø50	AL, BR	20
3/8", 1/2"	60	38	115	68	25	25	20.5	M6	Ø50	AL, BR	21
1/8", 1/4"	44	Ø48	111	68	25	25	17	M6	Ø50	SS	22
1/2"	58	Ø62	131	68	29	25	14	M6	Ø50	SS	26
VALVE TYPE : 20201											
1/8", 1/4"	50	50	124	68	25	25	17	M6	Ø50	AL, BR	23
3/8", 1/2"	65	50	124	68	25	25	14	M6	Ø50	AL, BR	24
3/8", 1/2"	58	Ø62	131	68	29	25	14	M6	Ø50	SS	25
1/4"	44	Ø48	111	68	25	25	17	M6	Ø50	SS	27

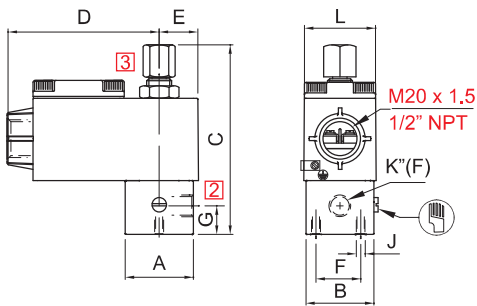

TERMINAL BOX/ Ex d ENCLOSURE, TYPE 16, 19, 37, 39, 58, 58LT

K (PORT SIZE)	A	B	C	D	E	F	G	J	L	BODY MATL.	CONST. REF.
VALVE TYPE : 20201											
1/8", 1/4"	38	38	103	85	22	25	16	M6	36	AL, BR	16
3/8", 1/2"	60	38	115	85	22	25	20.5	M6	36	AL, BR	17
1/8", 1/4"	44	Ø48	111	85	22	25	17	M6	36	SS	18
3/8", 1/2"	58	Ø62	131	85	22	25	14	M6	36	SS	19

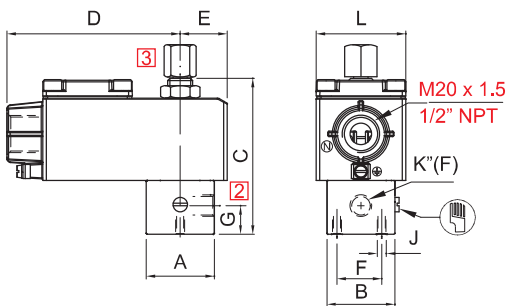

TERMINAL BOX/ Ex d LARGE ENCLOSURE, TYPE 16, 19, 37, 39, 58, 58LT, LC

K (PORT SIZE)	A	B	C	D	E	F	G	J	L	BODY MATL.	CONST. REF.
VALVE TYPE : 20201											
1/8", 1/4"	38	38	103	97	26	25	16	M6	50	AL, BR	20
3/8", 1/2"	60	38	115	97	26	25	20.5	M6	50	AL, BR	21
1/8", 1/4"	44	Ø48	111	97	26	25	17	M6	50	SS	22
1/2"	58	Ø62	131	103	29	25	14	M6	50	SS	26
VALVE TYPE : 20201											
1/8", 1/4"	50	50	124	103	28	25	17	M6	50	AL, BR	23
3/8", 1/2"	65	50	124	103	28	25	14	M6	50	AL, BR	24
3/8", 1/2"	58	Ø62	131	103	29	25	14	M6	50	SS	25
1/4"	44	Ø48	111	97	25	25	17	M6	50	SS	27