

Symbol

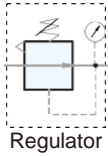

Features

1. Accurate and easy pressure setting.
2. Panel mounting is available.

How to order

UCR	-	02	N	G
Regulator		Port size	Thread	Gauge type
		02 :1/4"	Blank:G	Blank:Square
		03 :3/8"	N :NPT	G :Circle
		04 :1/2"	R :Rc	

Please contact our sales for non-relieving type.

*For non-relieving type, the secondary pressure is not allowed to be exhausted when it is higher than setting pressure.

Specifications

Model	UCR-02	UCR-03	UCR-04
Port size	1/4"	3/8"	1/2"
Fluid	Compressed air		
Regulator construction	Piston		
Body material	Aluminum die-cast		
Operating pressure range	0 ~ 9.9 kgf/cm ²		
Max. inlet pressure	15 kgf/cm ²		
Max. flow rate l/min (ANR)	2100	2130	2750
Ambient temperature	-10°C ~ 60°C		
Net weight	560g	550g	540g
Accessories	Mounting bracket set, Plug		
Option	Gauge plate, Panel nut		

Dimensions

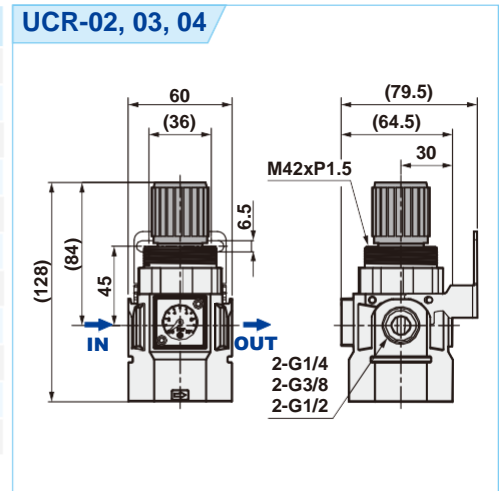

Flow chart

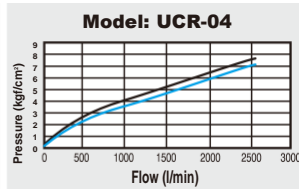
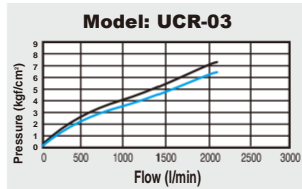
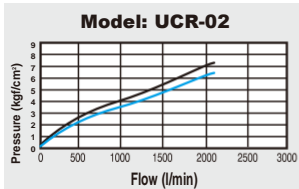

Note:

X axis: Flow (l/min)
Y axis: Pressure (kgf/cm²)
Blue line (P0) = Outlet pressure
Black line (P1) = Inlet pressure
P1-P0=Pressure range