

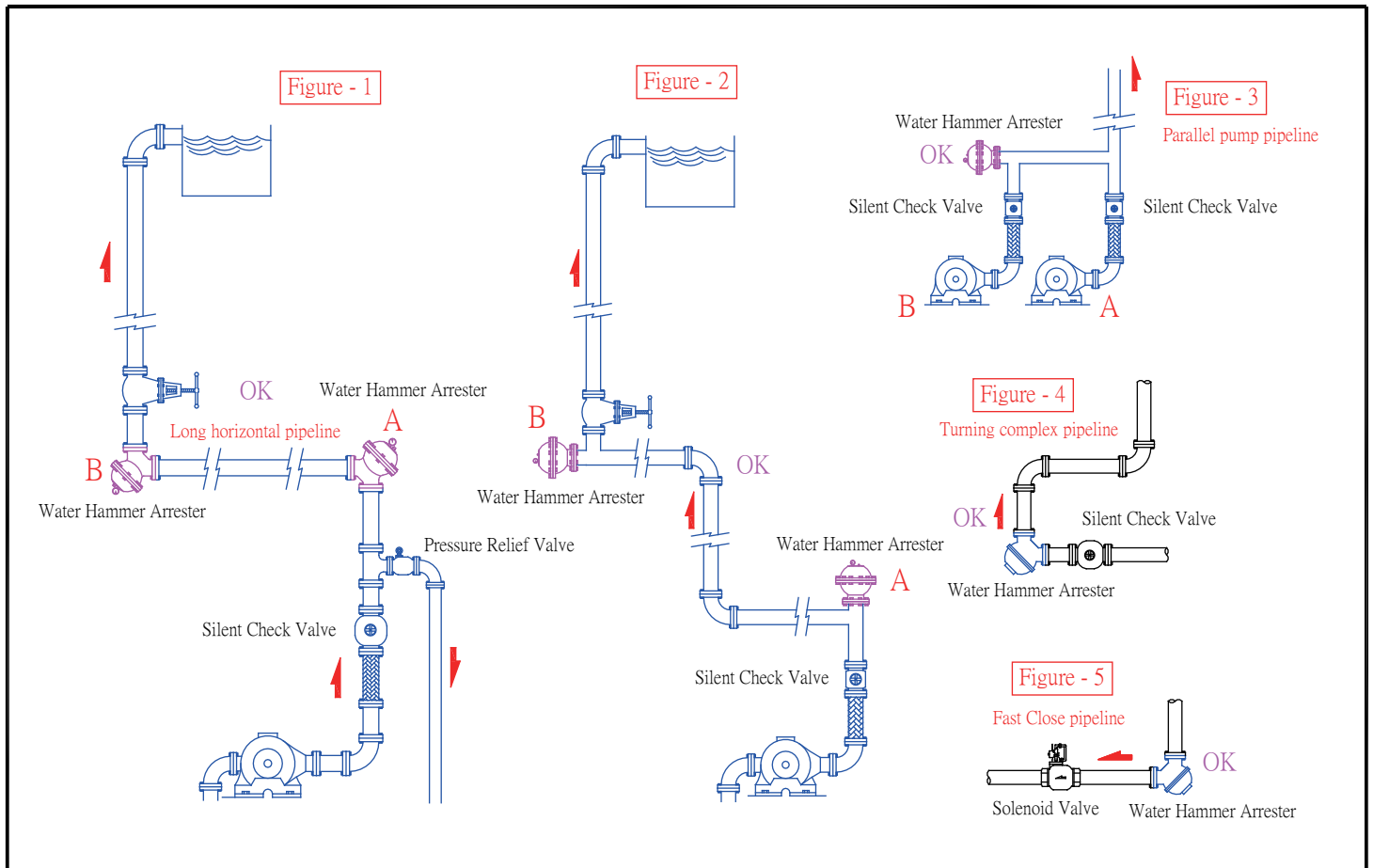

Z-Tide Valves

## INSTALLATION OF WATER HAMMER ARRESTER



- Figure 1. Generally, the water hammer effect happens above the check valve so installing a water hammer arrester can prevent the bad influence by water hammer effect. The length of horizontal pipe is longer than 50 meter in the figure 1, installing a water hammer arrester at corner between horizontal pipe and vertical pipe can avoid the water hammer effect.
- Figure 2. The distance between A and B is longer than 50 meter, installing a water hammer arrester at B can reduce the water hammer effect.
- Figure 3. Two pumps are used alternately; installing a water hammer arrester at horizontal pipe can avoid water hammer effect.
- Figure 4. There is an anfractuouse pipe line in the figure with a serious water hammer effect, installing a check valve at the lowest place of pipe line and installing a water hammer arrester above check valve can reduce the noise and vibration which make by water hammer effect.
- Figure 5. There are gate valves like solenoid valve or air operated valve which closes the gate very fast and produce the water hammer effect, installing a water hammer arrester at inlet of gate valve can reduce the noise and vibration which make by water hammer effect.